

[Home](#) ■ [Products](#) ■ [Storm & Sewer Equipment](#) ■ [Pumping Station Screens](#) ■ [HUBER Multi-Rake Bar Screen RakeMax®](#)

HUBER Multi-Rake Bar Screen RakeMax®



Reliable, sturdy travelling screen

- Very high screenings discharge capacity
- Low headloss
- Low installation height above ground level even in deep channels
- Control-independent safety system

The RakeMax® Screen is perfectly suited to both municipal and industrial wastewater and process water screening. The cleaning elements, attached to the chain system, can easily be adjusted to suit different requirements.

These elements can be conventional rakes, or brushes, or plastic wipers. As the cleaning elements are changeable, the screenings discharge capacity is then adjustable. This is especially favourable for high solids loads.

The installation height of the RakeMax® above ground level is very small and only dependent, even in case of deep channels, on the installation height of screenings transport or washing units.

Both ends of the cleaning elements are connected to drive chains. Each chain is driven by a sprocket on a common shaft and a flange mounted gear motor. Furthermore, defined meshing of the cleaning rakes with the bar rack ensures a high operating reliability. If the screen operation is blocked, a mechanical overload protection interrupts the operation.

The option RakeMax®-J offers additional extra high hydraulic throughput capacity and the advantage of screenings removal from the

bar rack starting straight at the channel bottom, in addition to all the well known benefits of the proven RakeMax®, i.e. reliable solids separation and high screenings discharge capacity.

Benefits

THE BENEFITS OF THE RAKEMAX® SCREEN AT A GLANCE:

- Very low headloss - high separation efficiency
- Defined meshing of the cleaning rakes with the bar rack ensures a high operating reliability.
- Screen installation possible without a bottom step
- Compact design with a low installation height above ground level
- Completely odour-encased screen with easy to remove covers
- Easy-to-retrofit into existing channels, installation without channel recesses possible
- The screen consists of a self-supporting folded stainless steel profile so that it can easily be lifted out of the channel.
- Not hindered by gravel or grit
- Simple and easy-to-access chain tensioning unit
- All parts in contact with medium (except the chain, drive and bearing) are made of immersion
- Pickled stainless steel, optional stainless steel chains
- High screenings discharge capacity through adjustable cleaning elements
- Independently replaceable rake and comb plates
- Optional screenings removal from the bar rack starting straight at the channel bottom plus extra high hydraulic throughput capacity with "J" option

Downloads

 [Brochure: HUBER RakeMax® Multi-Rake Bar Screen](#) [pdf, 421 KB]

 [Brochure: HUBER Detection System Safety Vision for impurity detection](#) [pdf, 300 KB]

Case Studies

- [HUBER expands activities in the field of water extraction: clean water through innovative system solutions for seawater and river water extraction](#)
- [The HUBER Multi-Rake Bar Screen RakeMax® – a success story with more than 3000 installed machines](#)
- [Unique innovation from the market leader: HUBER Detection System Safety Vision](#)
- [A Wastewater Screening and Screenings Processing Case Study at WWTP Hull \(Saltend\)](#)
- [HUBER Safety Vision increases the availability of machines](#)
- [Refurbishment project: regional STP Linz-Asten](#)
- [Case Study: Improvement of the Maer Lane STW Inlet Works](#)
- [Flawless operation and longevity make the RakeMax® Multiple Rake Screen invaluable to Guelph's Screening Process](#)
- [Major order: 12 HUBER Multi-Rake Bar Screens RakeMax® for Vienna](#)
- [Meadowhead STW Wastewater Case Study](#)
- [HUBER supplies the equipment for a major sewage treatment works in Berlin](#)
- [Huber Technology upgrades the Inlet works at Duncrue Street, Belfast - a Wastewater case Study](#)
- [Three HUBER RakeMax® screens for STW Magdeburg / Gerwisch](#)
- [HUBER supplies the machines for the mechanical treatment stage of the worlds' largest wastewater treatment plant project](#)
- [Great HUBER Bar Screens and Wash-Presses in Dublin](#)
- [Multi-Rake Bar Screen 2.0: the HUBER RakeMax® CF, an all-rounder with powerful hydraulics](#)
- [Up to 400 million litre capacity: HUBER successfully commissions 18 RakeMax® screens in the Madrid-Butarque stormwater retention basin](#)

Design Sketch

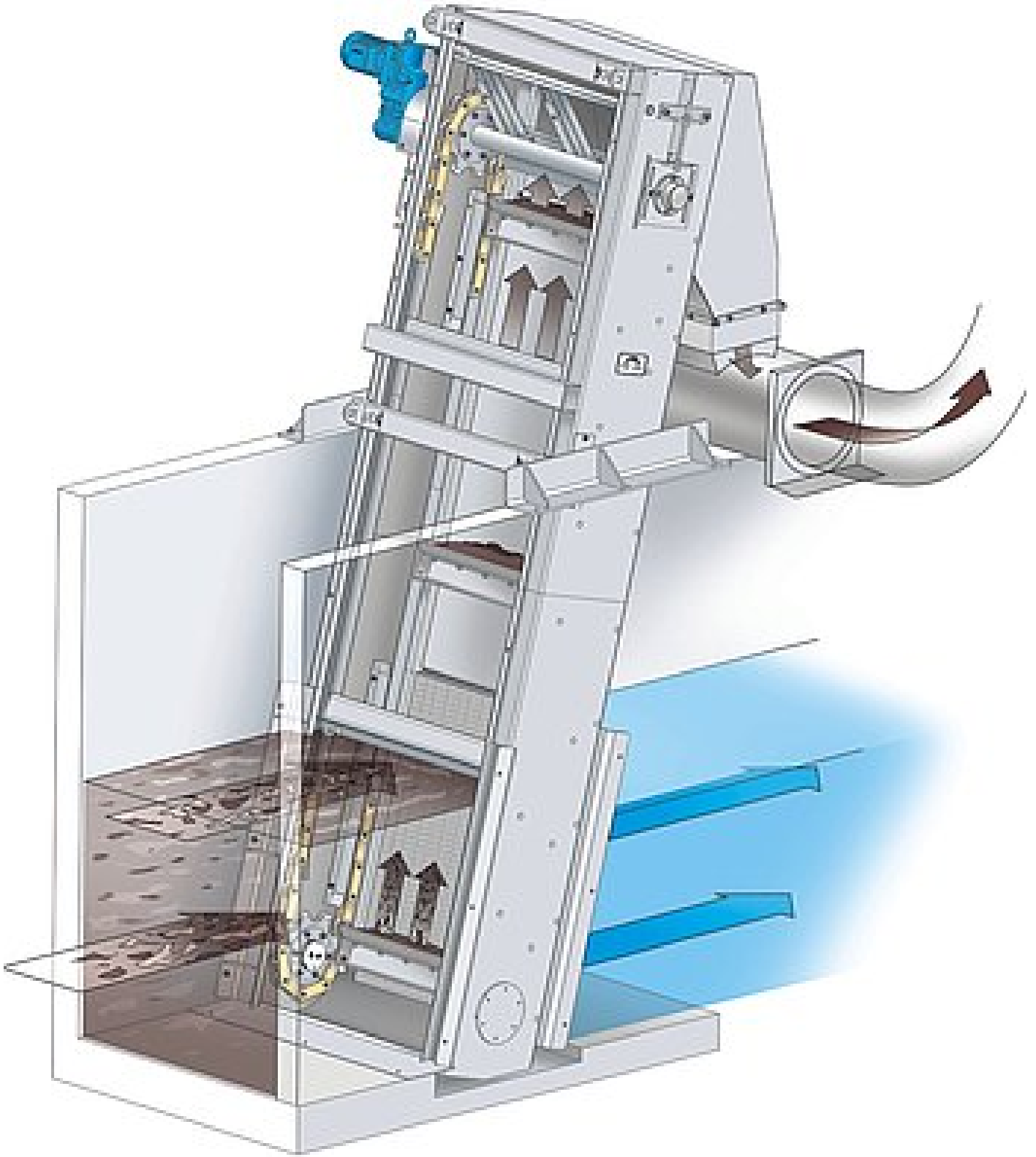

Media





Video: RakeMax® Multi-Rake Bar Screen for mechanical preliminary wastewater treatment at a municipal WWTP

<https://www.youtube.com/watch?v=SH3P8lpCDJM>



Video: HUBER RakeMax® Multi-Rake Bar Screen for coarse screening in meat processing industry

<https://www.youtube.com/watch?v=HvwV0BaLd68>

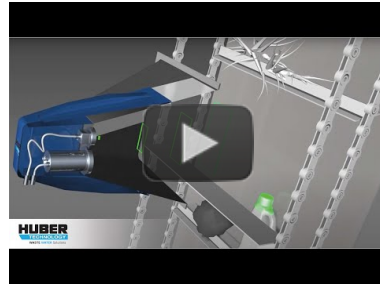

Animation: HUBER Safety Vision system for impurity detection

<https://www.youtube.com/watch?v=W1o94KTzHYs>

More products of this group: Pumping Station Screens

- [HUBER Pumping Stations Screen ROTAMAT® RoK4](#)



Hydroflux Pty Ltd
 Level 26, 44 Market St
 Sydney NSW 2000
 Australia

Phone +61 2 9089 8833
 Fax +61 2 9089 8830
 Email info@hydroflux.com.au
 WWW www.huber-technology.net.au

Representative of the HUBER group:
www.huber.de